



**WELDING  
AUTOMATION**

[LJwelding.com](http://LJwelding.com)

PRODUCT CATALOG 2017



**WELDING AUTOMATION & MATERIAL HANDLING EQUIPMENT  
RENTAL • NEW • USED • CUSTOMIZED**

# Table of Contents

<b>Welding Manipulators</b> .....	3
Gantry Beam Welding Systems.....	3
Boom & Column Manipulators.....	4
Manipulator & Gantry Options.....	5
MIG Welding Boom Mount.....	6
<b>Turning Rolls</b> .....	8
Pipe Alignment Rolls .....	8
Pipe Double-Jointing: Faster, Safer, Easier! .....	9
Growing Line.....	10
Tank Fit Up Rolls .....	11
Fixed Height Turning Rolls .....	12
Vessel Turning Rolls – Height Adjustable.....	13
Pipe Rolls – Height Adjustable .....	14
Pipe Rolls – Height Adjustable & Benchtop.....	15
<b>Pipe Stands</b> .....	16
Modular Roller Support Stands .....	16
Jack Stands & Tripods.....	17
<b>Welding Positioners</b> .....	18
Gear Tilt Positioners .....	18
Pipe Turning Positioners .....	19
High Volume Pipe Spooling Cell .....	20
Turnkey Welding Systems .....	21
Powered Headstock Positioners.....	22
Powered Height, Tilt & Rotate Positioners .....	23
Portable & Benchtop Positioners .....	24
Low Profile Turntables .....	25
<b>Positioner Accessories</b> .....	26
Grippers & Chucks .....	26
Elbow Jigs .....	26
<b>Automation &amp; Controls</b> .....	27
Controls Panels.....	27
Foot Switches.....	27
Hand Pendants.....	27
Automation Capabilities.....	27
<b>Custom Pipe Handling Systems</b> .....	28
Pipe & Structural Steel Conveyor Systems.....	28
<b>Cable Reel Rollers</b> .....	29
<b>Beam Clamp Rigging Rollers</b> .....	30
<b>Pipeline Roller Equipment</b> .....	31

# Gantry Beam Welding Systems

Gantry welding systems are used for longitudinal welding of long structural beams. Typically, two independent submerged arc welding systems are utilized to maximum productivity, complete with individual weld seam tracking, camera, and torch adjustability systems.

**DEPOSITION RATES UP TO 52 LBS/HR**

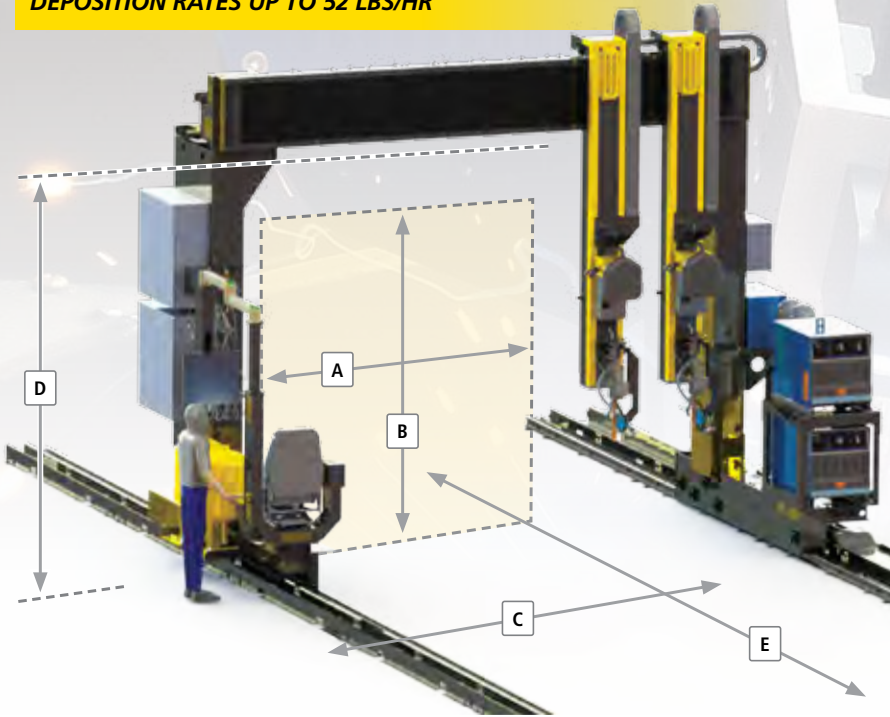

Dimensions A through E, fully customizable

## Easy to Customize

LJ Welding's gantry systems are used for longitudinal welding of long structural beams and are built to order for every customer. Welding gantry systems come complete with two welding stations, weld seam tracking, camera systems and torch adjustability

### Customize Work Area & Footprint

- ✓ Working area width/height (A/B)
- ✓ Overall gantry width/height/rail length (C/D/E)

### CUSTOMIZE STANDARD FEATURES

- ✓ Dual 1,000A sub-arc typically set up in twin or tandem wire mode, sized to customer requirements
- ✓ Seam tracking system – choose mechanical (probe) or vision (laser)

### SELECT OPTIONAL FEATURES

- ✓ Induction or flame preheat system
- ✓ MIG or CMT welding systems

### Typical Max. Deposition Rates\*

	Single Weld Head	Dual Weld Head
<b>Single Wire</b>	Up to 20 lbs/hr	Up to 40 lbs/hr
<b>Twin Wire</b>	Up to 26 lbs/hr	Up to 52 lbs/hr

\* Using 1,000 amp sub-arc power source.



Select HMI or custom control options, sub-arc or open arc camera systems, and probe or laser seam tracking systems



Choose from a complete line of modular supports for structural steel, pipe and vessels up to 60 tons and more



Specify onboard twin or tandem SAW, MIG or CMT configurations, flux delivery, recovery and heating systems

# Boom & Column Manipulators

LJ engineers and manufactures manipulators with boom stiffness and welding head stability, operator controls, and ease of use as key driving factors. Automatic welding heads are designed to be mounted on a stiff and nearly vibrationless boom, and moved to desired height with powered column. The welding head can then be positioned as required for automated welding of large vessels or structural steel.

## CUSTOM SIZES AVAILABLE

### Typical Max. Deposition Rates\*

Single Wire	Up to 20 lbs./hr
Twin Wire	Up to 26 lbs./hr

\* Using 1,000 amp sub-arc power source.



MNP-600 4' x 5'

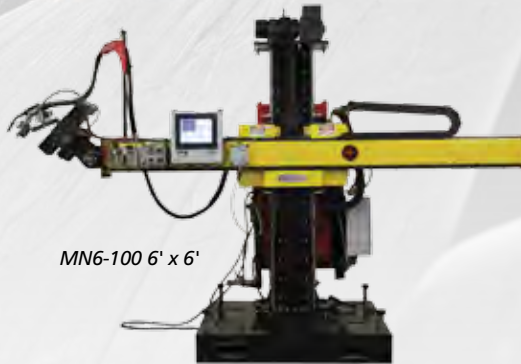

MN6-100 6' x 6'



MN12-200 12' x 12'

SPECIFICATIONS	MNP-600 4' x 5'	MN6-100 6' x 6'	MN9-300 9' x 9'	MN12-200 12' x 12'	MN16-100 16' x 16'
Load Capacity (at Boom End):	250 lbs	500 lbs	500 lbs	500 lbs	250 lbs
Boom Stroke:	42"	72"	108"	144"	192"
Column Stroke:	58"	72"	108"	144"	192"
Power Requirements:	480 V, 3-ph*	480 V, 3-ph*	480 V, 3-ph*	480 V, 3-ph*	480 V, 3-ph*
Equipment Mass:	4,400 lbs	7,500 lbs	8,500 lbs	9,000 lbs	9,500 lbs

\* 208 - 600 V, 50 or 60 Hz input power options available. Specifications subject to change; consult factory for all specifications.

### Available Options

- Control platform (Joystick or fully integrated touchscreen options)
- SAW or GMAW welding systems (Single, Twin, or Tandem wire)
- Powered cross slides (1 or 2 axis)
- Weld Camera systems (SAW or Open Arc)
- Seam Tracking (Vision/Laser or Tactile/Mechanical)
- Travel Car (Powered or Manual)
- Pre-heating system (Rolling Induction Heater)
- Flux Recovery and delivery systems

### Standard Features

- 480Volt, 3Phase input power (Other voltages available)
- Boom Traverse, Mast Traverse and Travel Car Speed: 5-120 in/min
- Swivel base (just under 360° range)
- Variable speed boom and column controls (in/out, up/down)



Fully or semi-automate any welding system

# Manipulator & Gantry Options



## Camera Systems

Subarc or open arc options; allows for easier set up of weld torch and safer viewing for operator throughout the welding process



## Seam Tracking

Seam tracking for fully automated welding processes complete with simple user interface. Laser (vision) or tactile (mechanical probe) style options available

Free standing or powered rail car options c/w safety shut off bumpers



## Powered Cross Slides & Joystick Controller

Standard 6" x 6" travel range and 200lb payload. Available with regular joystick, oscillation, or servo controls.



## Control Options

Optional user-friendly HMI touch screens to control all functions

## Power Sources

LJ can integrate any welding process or power source, including submerged arc (SAW), MIG, or CMT processes



Miller SubArc



Lincoln SubArc



Fronius CMT



Optional fully integrated rolling induction heating systems



For subarc applications, any combination of flux delivery and recovery systems



# MIG Welding Boom Mount

## EXTREME PRECISION AND WELD QUALITY

Ideal for busy shops where floor space is limited, tripping hazards are a concern, and maximum operator on-arc time is required.

Manual GMAW (MIG) processes that are otherwise difficult to reach are made more convenient using LJ's innovative WSM-200 MIG welding boom. Often used as a standalone process, or as a convenient root weld pass system for heavy wall tanks or vessels prior to submerged arc fill passes.

## RIGID CONSTRUCTION AND UNBENDING RELIABILITY AT YOUR SHOP OR JOB SITE

LJ's WSM-200 MIG welding booms are chosen for their:

- ✓ Boom & column resistance from adjustable drag brakes
- ✓ Smooth motion from tapered roller bearings
- ✓ Customizable boom end mounts using two rotating equipment platforms
- ✓ Total coverage - double articulated boom ensures no dead zones in your work area while optimizing limited floor space

Ask LJ Welding to engineer an end-to-end welding productivity solution that will improve part quality, maximize output and increase overall profitability.

## POPULAR FOR MANUFACTURING IN:

- ✓ Tank and vessel construction
- ✓ Trailer and railcar fabrication
- ✓ Wind tower fabrication
- ✓ Mining equipment
- ✓ Pipeline fitups

## CUSTOMIZE YOUR WELDING JOB

- ✓ 110V power
- ✓ Air hose
- ✓ Grinder holster
- ✓ Wire Feed Controller
- ✓ Optional turntable for wire drum
- ✓ Optional rail mount
- ✓ Integrates with any welding power source



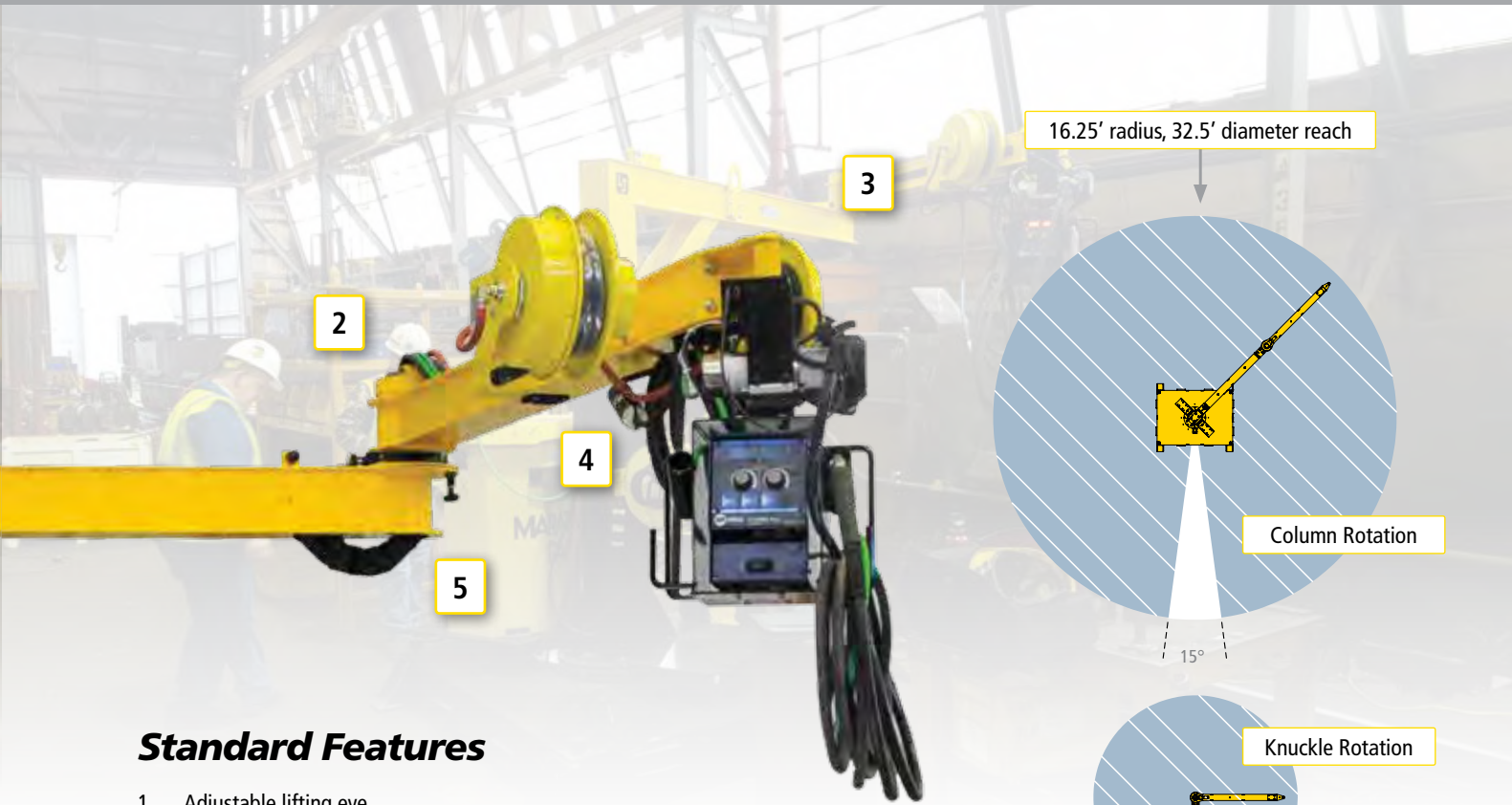

16.25' radius, 32.5' diameter reach

Column Rotation

15°

Knuckle Rotation

30°

### Standard Features

1. Adjustable lifting eye
2. Adjustable drag brake sets boom resistance.
3. Customizable boom end mount
4. Integrated cable management channels
5. Boom knuckle lock (pull and twist for free rotation)
6. Hitch pin height adjustment
7. (2) Equipment mounting locations (platforms rotate with column)
8. Adjustable drag brake sets column rotation resistance.
9. Column lock (pull and twist for free rotation)
10. Concrete-filled counterweight base with forklift pockets on all sides

**LOAD UP TO 250 LBS.  
16' OR CUSTOM RADIUS**

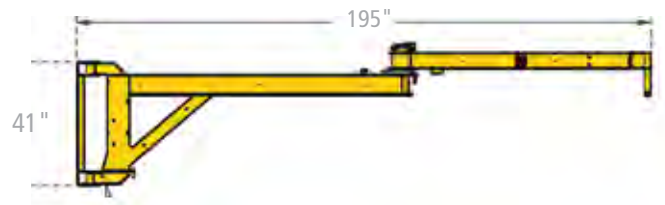

#### SPECIFICATIONS

#### WSM-200

Area Coverage:*	16" or custom size
Max. Working Height:	110"
Max. Boom Height:	141"
Vertical Adjustment:	Up to 32"
Max. Boom Reach:	195"(16.25')
Base Dimensions:	65" – 74"
Approx. Shipping Weight:	5,100 lbs

\* May be customized to your requirements.

### Wall Mount Option

#### SPECIFICATIONS

#### WSM-200WM

Capacity:	250 lbs
Working Length:	195"

*Automate with an LJ welding positioner or turning roll set for optimum productivity*

# Pipe Alignment Rolls

LJ alignment rolls are often used in pipe double-jointing systems for maximum efficiency & safety, with up to 65% decrease in fit up cycle times.

Alignment rolls are ideal for:

- ✓ Fast & precise alignment of pipe or vessel
- ✓ Fine leveling and side shift for fast fit up
- ✓ Compensating for inconsistencies in shop floor or ground

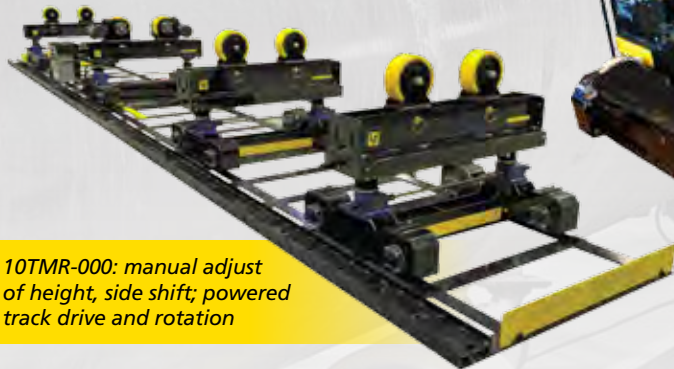

10TMR-000: manual adjust of height, side shift; powered track drive and rotation



20TSR-100/200: powered side shift, elevation, tracked drive and rotation

SPECIFICATIONS	10TMR-000 10-Ton	20TSR-100/200 20-Ton
Load Capacity:	Driver: 10,000 lbs Idler: 10,000 lbs	Driver: 20,000 lbs Idler: 20,000 lbs
Vessel Diameter Range:	6" – 96"	6" – 60"
Tractive Effort: Output Torque:	Dual Drive, 3,400 lbs 17,000 in-lbs	Single Drive 5,700 lbs 40,000 in-lbs
Power Requirements:	110 V, 1-ph*	480 V, 3-ph*
Rotation Speed:	5-50 in/min	0-80 in/min

\* 208 - 600 V, 50 or 60 Hz input power options available. Specifications subject to change; consult factory for all specifications.

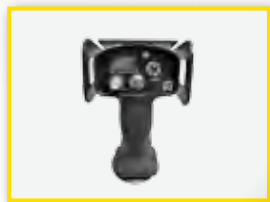

Cabled or wireless hand pendant with or without digital readout



Easy to use HMI touchscreen to control hydraulic jacking, alignment, indexing/track drive, and powered rotation



Rail-mount base - can be supplied as motorized or non-motorized for driving pipe sections together



Variable speed and bidirectional controls for rotation, alignment, leveling and/or rail mount drive



# Pipe Double-Jointing: Faster, Safer, Easier!

LJ responded to customer demand and now offers turnkey pipe joining systems, for maximum productivity and safety. Complete pipe handling and welding automation functionality is fully integrated into a single user-friendly system. The result is up to a 65% decrease in cycle times for double-jointing and pipe welding applications.

**PLUG & PLAY WITH  
SAW MANIPULATORS FOR  
MAXIMUM THROUGHPUT**



## Fully Automated Pipe Joining Systems



Pipe loaded, lined up using track drive



Alignment, side shift, and leveling functionality



Available with fully integrated subarc manipulators or robotic welding systems



Optional Tailstock system available for adding flanges or end caps

# Growing Line

LJ specializes in an innovative growing line system used for fast alignment, leveling, fit up and indexing of large pipe and vessels up to 80 tons and 20 ft diameter or more. Growing lines can reduce fit up time by up to 65% when compared with traditional methods, minimize crane handling and maximize operator safety.

**MINIMIZE CRANES & REDUCE FIT UP TIMES BY UP TO 65%**



Easy to use HMI touchscreen to control hydraulic jacking, alignment, indexing/track drive, and powered rotation

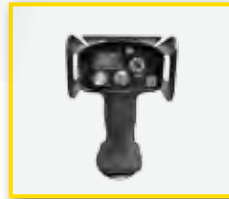

Cabled or wireless pendants plug and play with main control console to any operator preference

## SPECIFICATIONS

	40TA-000 Growing Line	60TA-000 Growing Line	80TA-100 Growing Line
Load Capacity:	80,000 lbs.	120,000 lbs.	160,000 lbs
Diameter Range:	24" – 240"	24" – 240"	24" – 240"
Minimum Workpiece Length:	144"	144"	144"
Rotation Speed:	5-50 in/min	5-50 in/min	5-50 in/min
Track Drive Speed:	12-120 in/min	12-120 in/min	12-120 in/min
Input Power:	480V, 3-ph*	480V, 3-ph*	480V, 3-ph*

\* 208 - 600 V, 50 or 60 Hz input power options available. Specifications subject to change; consult factory for all specifications.



Each section loaded onto rolls



Sections brought together using powered track drive



Alignment, leveling and high/lows easily adjustable using pendant or touch screen control



Ready for fit up and/or automated welding, then index for next section to be added

# Tank Fit Up Rolls

For fit up of thin walled or difficult to handle tanks where extra lateral support, alignment and line up of tank sections is required.

Benefits include:

- ✓ Fast & easy addition of sections for longer tank
- ✓ Maintaining workpiece cylindrical shape by supporting the entire length of the tank or vessel
- ✓ Fast and safe alignment and fit up capabilities

Full control over tank fit up process using control pendant or touch screen



ALG-412



ALG-512

## SPECIFICATIONS

SPECIFICATIONS	ALG-412 Roller Bed Style	ALG-512 Fully Automated Fit Up Rolls
Load Capacity:	Up to 60 tons	Up to 20 tons
Diameter Range:	3' – 14'	5' – 14'
Drive System:	Dual drive, drive-shaft free style	Dual drive, drive-shaft free style
Tractive Effort:	6,000 lbs	6,000 lbs
Power Requirements:	480 V, 3-ph*	480 V, 3-ph*
Rotation Speed:	5-96 in/min	5-96 in/min
Equipment Mass:	8,300 lbs (5 sections)	11,300 lbs (5 sections)

\* 208 - 600 V, 50 or 60 Hz input power options available. Specifications subject to change; consult factory for all specifications.

## Features & Options



Hydraulic alignment jacking system to align and pull vessel sections together



Modular construction allows for multiple lengths to be added for longer vessels

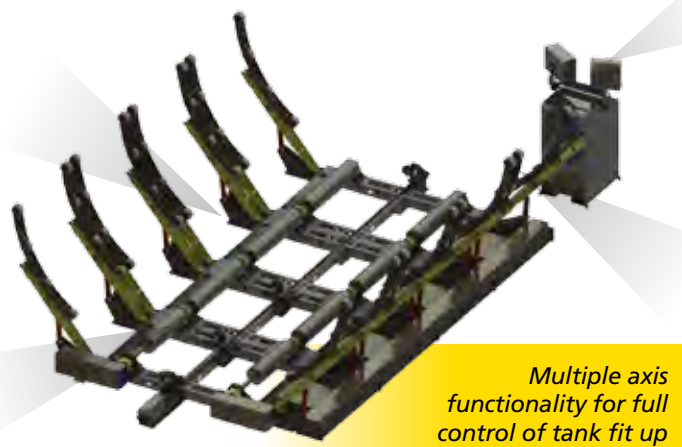

Multiple axis functionality for full control of tank fit up



Integration with automated LJ welding manipulators



Side Jigs to eliminate thin-wall vessel sagging

# Fixed Height Turning Rolls

LJ turning rolls have the largest diameter range and load capacities in their class.



SPECIFICATIONS	80T-700/80T-800 80-Ton	120T-500/120T-600 120-Ton	200T-500/200T-600 200-Ton
<b>Load Capacity:</b>	Driver: 80,000 lbs Idler: 80,000 lbs	Driver: 120,000 lbs Idler: 120,000 lbs	Driver: 200,000 lbs Idler: 200,000 lbs
<b>Vessel Diameter Range:</b>	1.5' – 26'	1.5' – 26'	1.5' – 26'
<b>Footprint:</b>			
<b>Idler:</b>	50" x 174" x 32" (top of wheel)	50" x 184" x 31" (top of wheel)	50" x 184" x 31" (top of wheel)
<b>Driver:</b>	36" x 162" x 32" (top of wheel)	36" x 162" x 31" (top of wheel)	36" x 162" x 31" (top of wheel)
<b>Tractive Effort:</b>	Dual Drive 12,000 lbs	Dual Drive 20,400 lbs	Dual Drive 20,400 lbs
<b>Output Torque:</b>	120,000 in-lbs	240,000 in-lbs	240,000 in-lbs
<b>Power Requirements:</b>	480 V, 3-ph*	480 V, 3-ph*	480 V, 3-ph*
<b>Operation Speed Range:</b>	5-50 in/min	7-70 in/min	7-70 in/min

\* 208 - 600 V input power options available. All LJ turning rolls available with digital speed readout calibrated to inches/min or mm/min for precise welding speed control. Specifications subject to change; consult factory for all specifications.

Fixed height turning rolls are useful for:

- ✓ Quick change-overs between different sized work pieces
- ✓ Maximizing ease & quality of welds using synchronized rotation
- ✓ Seamless integration with manipulator applications

## Features & Options

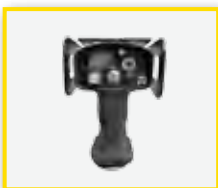

Cabled or wireless hand pendant with or without digital readout

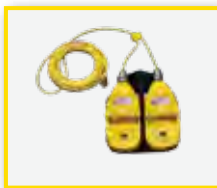

Bi-directional or variable speed foot switches



# Vessel Turning Rolls – Height Adjustable

Dual adjustable drive heads designed such that load can be centered on rolls.

Height adjustable turning rolls ensure:

- ✓ Quality control by maintaining a constant centerline
- ✓ Faster cycle times from reduced changeover effort
- ✓ Ease of welding using height adjusts for optimal weld performance



06R-100/200 12-Ton



10TRV-100/200 20-Ton



20TRV-100/200 40-Ton

**WIDE BODY FRAMES FOR UP TO 20' OD AVAILABLE**

## SPECIFICATIONS

SPECIFICATIONS	06R-100/200 12-Ton	10TRV-100/200 20-Ton	20TRV-100/200 40-Ton
<b>Load Capacity:</b>	Driver: 12,000 lbs Idler: 12,000 lbs	Driver: 20,000 lbs Idler: 20,000 lbs	Driver: 40,000 lbs Idler: 40,000 lbs
<b>Vessel Diameter Range:</b>	0.5'– 12'	1'– 14'	1'– 14'
<b>Footprint:</b>	34" x 103" x 26"	113" x 44" x 33"	116" x 44" x 31"
<b>Height Adjustability:</b>	23" – 39" (top of wheel) Adjustable in 3" increments	27" – 45" (top of wheel) Adjustable in 3" increments	30" – 48" (top of wheel) Adjustable in 3" increments
<b>Tractive Effort: Output Torque:</b>	Single Drive 3,500 lbs 25,000 in-lbs	Dual Drive 6,000 lbs 50,000 in-lbs	Dual Drive 8,700 lbs 80,000 in-lbs
<b>Power Requirements:</b>	110 V, 1-ph*	480 V, 3-ph*	480 V, 3-ph*
<b>Operation Speed Range:</b>	5-50 in/min	5-50 in/min	5-50 in/min

\* 208 - 600 V input power options available. Specifications subject to change; consult factory for all specifications.

## Standard Features

Adjustable height with mountable track

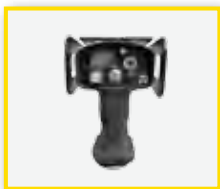

Cabled or wireless hand pendant with or without digital readout

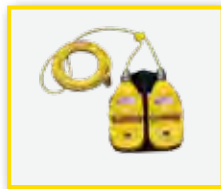

Bi-directional or variable speed foot switches

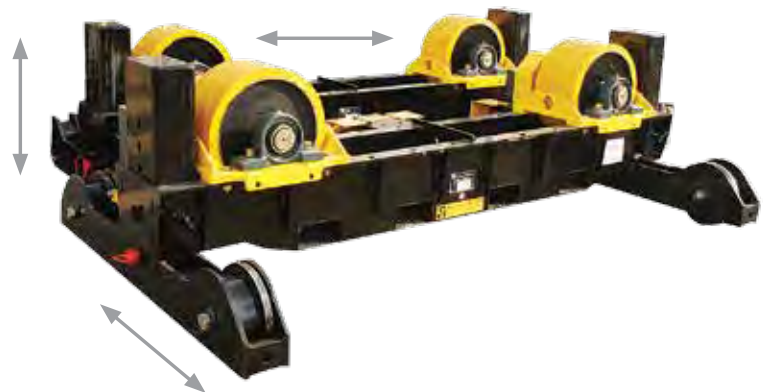

# Pipe Rolls – Height Adjustable

LJ pipe rolls are used for pipe welding applications ranging from light tubes to extra-heavy walled pipe. Whatever your pipe rolling application, LJ has the most cost effective and user friendly equipment.



SPECIFICATIONS	SHD-700/SHD-750 8-Ton Low Profile Pipe Roll	SHD-800/SHD-850 8-Ton Geared Height Adjust
Load Capacity:	Driver: 8,000 lbs Idler: 8,000 lbs	Driver: 8,000 lbs Idler: 8,000 lbs
Pipe Diameter Range:	2" – 48"	2" – 48"
Footprint:	34" x 50" x 21"	36" x 50" x 29"
Height Range:	14" – 26" (top of wheel) Adjustable in 1" increments	29" – 41" (top of wheel) Manual or Powered geared height adjustable
Tractive Effort: Output Torque:	Single Drive, 2,400 lbs tractive effort 12,000 in-lbs output torque	Single Drive, 2,400 lbs tractive effort 12,000 in-lbs output torque
Power Requirements:	110 V, 1-ph*	110 V, 1-ph*
Operation Speed Range:	5-50 in/min	5-50 in/min

\* 208 - 600 V, 50 or 60 Hz input power options available. Specifications subject to change; consult factory for all specifications.

## Features & Options

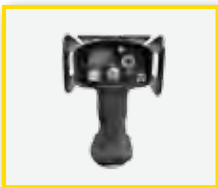

Cabled or wireless hand pendant with or without digital readout

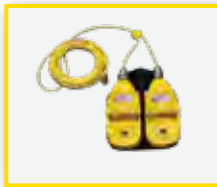

Bi-directional or variable speed foot switches



Dual drive available

# Pipe Rolls – Height Adjustable & Benchtop

LJ's pipe rolls are built for reliability and endurance for the longest possible service life. They offer precise rotation for pipe fabrication and designed to require minimal floor space.

**IDEAL FOR SUPPORTING & TURNING HEAVY WALL PIPE**



BPR-100/200



HD2L-100/150



EMCC-300

## Base Foot Options

Choose foot options based on your application's requirements.



STANDARD

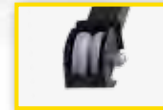

RAIL MOUNT

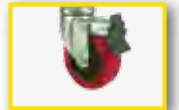

LOCKING CASTERS

SPECIFICATIONS	BPR-100/200 1.5-Ton Benchtop Roller	HD2L-100/150 4-Ton Pipe Roller	EMCC-300 4 Ton Pipe Roller & Cart
Load Capacity:	Driver: 1,500 lbs Idler: 1,500 lbs	Driver: 4,000 lbs Idler: 4,000 lbs	Driver & Idler System: 8,000lbs
Pipe Diameter Range:	2" – 16"	2" – 36"	2" – 36"
Footprint:	26" x 13" x 10"	30" x 31" x 40"	69" – 116" x 39" x 49"
Height Range:	Low Profile, Fixed Height	28" – 40"	37" – 49"
Tractive Effort: Output Torque:	Single Drive, 270 lbs 1,300 in-lbs	Single Drive, 650 lbs 2,000 in-lbs	Single Drive, 650 lbs 2,000 in-lbs
Power Requirements:	110 V, 1-ph*	110 V, 1-ph*	110 V, 1-ph*
Operation Speed Range:	8-80 in/min	8-80 in/min	8-80 in/min

\* 208 - 600 V, 50 or 60 Hz input power options available. Specifications subject to change; consult factory for all specifications.

## Features & Options

Optional base for Benchtop Rolls

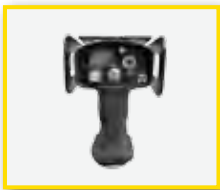

Cabled or wireless hand pendant with or without digital readout



Bi-directional or variable speed foot switches



# Modular Roller Support Stands

LJ's modular pipe support stands offer a range of customizable options that will meet your application's needs. LJ can also custom engineer your stands for welding applications that require unique solutions.

## Top Options



Flat Roller Top



Sawhorse Top



Multidirectional Rollers



Vee-Rollers

## Base Units



**MODULAR DESIGN,  
MAXIMUM FLEXIBILITY**

SPECIFICATIONS	HD2L-200U 4,000 lbs	HD2-300U 4,000 lbs	SHD-850 8,000 lbs	UHD-200 16,000 lbs
Load Capacity:	4,000 lbs	4,000 lbs	8,000 lbs	16,000 lbs
Diameter Range:	2" – 48"	2" – 48"	4" – 48"	8" – 60"
Height Range:	24" – 36"	39" – 63"	30" – 42" (Dual screw jack geared height adjust)	30" – 42" (Dual screw jack geared height adjust)
Footprint:	30" x 31" x 26" (top of wheel)	34" x 31" x 40" (top of wheel)	36" x 50" x 29" – 41" (top of wheel)	43" x 51" x 29" – 41" (top of wheel)
Weight:	138 lbs	165 lbs	450 lbs	530 lbs

Specifications subject to change; consult factory for all specifications.

## Base Foot Options

STANDARD



Self Leveling Flat Foot

FOR RAIL TRACK



Rail Mount Caster Kit

FOR MOBILITY

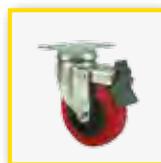

Swivel Caster Kit with Brakes





# Jack Stands & Tripods

HDJ-style roller supports provide the widest range of features available, including geared height adjustability, braking base casters, ratchet hold down straps, fork lift pockets, and extra heavy duty frame design.

**GEARED HEIGHT ADJUST UNDER LOAD**



SPECIFICATIONS	HDJ2C-100 4,000 lb Geared Height/Roller Base	HDJ5C-100 10,000 lb Geared Height/Roller Base
Load Capacity:	4,000 lbs	10,000 lbs
Diameter Range:	2" – 36"	4" – 48"
Height Range:	27" – 39"	27" – 39"
Footprint:	38" x 24" x 28" (top of wheel)	48" x 28" x 28" (top of wheel)
Equipment Mass:	191 lbs	429 lbs

## Built-in Safety Features



Geared height adjust easily changes working heights under load

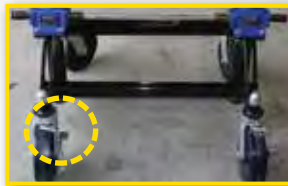

Braking base caster securely lock wheels into position



Ratchet strap system for safe hold down, handling, or moving pipe



Forklift pockets for safe & easy transportation

## Modular Tripod Stands



Flat Roller Top



Sawhorse Top



Multidirectional Rollers



Vee-Rollers



LD255-100



TS3 Series

SPECIFICATIONS	LD255-100 2,500 lb Roller Tripod	TS3-160V 5,000 lb	TS3-280V 5,000 lb	TS3-330V 5,000 lb
Load Capacity:	2,500 lbs	5,000 lbs	5,000 lbs	5,000 lbs
Diameter Range:	2" – 28"	2" – 28"	2" – 28"	2" – 28"
Height Range:	21" – 33"	16" – 25"	28" – 44"	33" – 56"
Footprint:	23" x 26" x 26"	26" x 26" x 21"	33" x 33" x 21"	33" x 33" x 21"
Equipment Mass:	60 lbs	39 lbs	53 lbs	58 lbs

Specifications subject to change; consult factory for all specifications.

# Gear Tilt Positioners

Gear tilt positioners are used for powered, variable speed tilting and rotation to automate and increase welding productivity of cumbersome, heavy work pieces.

LARGER CAPACITY MODELS AVAILABLE



1PT-300



2PT-300



T12PS-100



T24PS-100

SPECIFICATIONS	1PT-300 3,000 lbs	2PT-300 6,000 lbs	T12PS-100 12,000 lbs	T24PS-100 24,000 lbs
<b>Load Capacity:</b>	3,000 lbs (at 0" overhung load) 1,700 lbs (at 12" overhung load)	6,000lbs (at 0" overhung load) 4,570lbs (at 12" overhung load)	12,000lbs (at 0" – 12" overhung load)	24,000 lbs (at 0" – 12" overhung load)
<b>Footprint:</b>	64" x 48" x 35"	64" x 59" x 35"	89" x 60" x 59"	96" x 71" x 62"
<b>Tilting Torque:</b>	35,000 in-lbs	80,000 in-lbs	250,000 in lbs	550,000 in-lbs
<b>Tilting Speed:</b>	0.1-0.9 RPM (135° in 25 seconds)	0.1-0.9 RPM (135° in 25 seconds)	0.05-1.00 RPM (135° in 23 seconds)	00.05-1.0 RPM (135° in 23 seconds)
<b>Height Adjustability:</b>	29" – 49" center height adjustment in 5" increments	30" – 50" center height adjustment in 5" increments	48" – 80" center height adjustment in 4" increments	50.5" – 82" center height adjustment in 4" increments
<b>Table Diameter:</b>	26" (available with 48" OD slotted faceplate)	32" (available with 48" OD slotted faceplate)	48" OD faceplate with 6" x 3/4" slots	60" OD faceplate with 6" x 1" slots
<b>Power Requirements:</b>	110V, 1-ph*	480V, 3-ph*	480 V, 3-ph*	480 V, 3-ph*
<b>Rotation Speed:</b>	0.1–2.2 RPM	0.1–2.2 RPM	0.05–2.2 RPM (Other speed options available)	0.05–1.2 RPM (Other speed options available)
<b>Turning Torque:</b>	20,000 in-lbs	40,000 in-lbs	125,000 in-lbs	250,000 in-lbs
<b>Ground Capacity:</b>	800 Amps	800 Amps	1500 Amps	1500 Amps

\* 208 - 600 V, 50 or 60 Hz input power options available. Ground Capacity: up to 2500 Amps available. Specifications subject to change; consult factory for all specifications.

## Features & Options

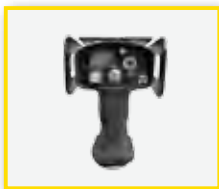

Cabled or wireless hand pendant with or without digital readout

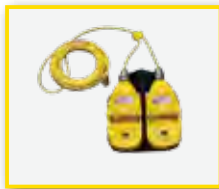

Bi-directional or variable speed foot switches



Grippers up to 60" OD



Fully integrated with manipulators or robotic welding

# Pipe Turning Positioners

LJ's pipe turning positioners are used for positioning heavy-wall, large diameter pipe for spooling application with large offset loads.

**LARGE HEIGHT ADJUSTABILITY  
ACCOMMODATES A WIDE RANGE  
OF SWING DIAMETERS**



**NEW- UP TO 60,000 LBS CAPACITY**

SPECIFICATIONS	16P-700	30P-200	P12PS-100	P24PS-100	P60PS-200
	3,000 lbs	5,400 lbs	12,000 lbs	24,000 lbs	60,000 lbs
Load Capacity:	3,000 lbs (at Mounting Plate)	5,400 lbs (at Mounting Plate)	12,000 lbs (at Mounting Plate)	24,000 lbs (at Mounting Plate)	60,000 lbs (at Mounting Plate)
Footprint:	72" x 42" x 77"	72" x 42" x 77"	96" x 71" x 62"	96" x 71" x 69"	133" x 96" x 105"
Turning Torque:	20,000 in-lbs (With Counterweight)	40,000 in-lbs	125,000 in-lbs	250,000 in-lbs	800,000 in-lbs
Height Adjustability:	45" – 69" in 4" increments	33" – 69" in 4" increments	48" – 96" in 6" increments	48" – 96" in 6" increments	73" – 145" in 8" increments
Power Requirements:	110V, 1-ph*	480V, 3-ph*	480V, 3-ph*	480V, 3-ph*	480V, 3-ph*
Operation Speed:	0.3–3.0 RPM	0.2–2.4 RPM	0.05–1.2 RPM	0.05–1.2 RPM	0.04–0.8 RPM
Ground Capacity:	400 Amps	800 Amps	1,500 Amps	1,500 Amps	1,500 Amps

\* 208–600 V, 50 or 60 Hz input power options available. Ground Capacity: up to 2500 Amps available. Pipe Stands: various capacities with gear or manual elevation. Specifications subject to change; consult factory for all specifications.

## Features & Options

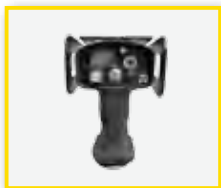

Cabled or wireless hand pendant with or without digital readout

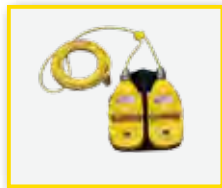

Bi-directional or variable speed foot switches



Grippers up to 60" OD



Maximize your productivity with fully integrated welding systems

# High Volume Pipe Spooling Cell

LJ's pipe spooling cells significantly accelerate pipe fabrication cycle times, compared to conventional material handling and low deposition rate welding processes.

The high volume pipe spooling cell removes cumbersome and time-consuming steps, streamlining your entire pipe spool welding process, while efficiently utilizing limited shop floor space.



**MAXIMUM EFFICIENCY  
MATERIAL HANDLING**



**INNOVATIVE WELDING  
AUTOMATION**



**MAXIMUM PIPE FABRICATION  
PRODUCTIVITY & ROI**



## Customize Your Own System

### 1. Welding Manipulator

- ✓ Subarc or Open Arc (MIG, CMT)
- ✓ Deposition rates up to 30+ lbs/hr

### 2. Positioner Systems

- ✓ Capacity: 1,000 - 20,000+ lbs
- ✓ Grippers: up to 72" OD, 24,000lbs capacity
- ✓ Elbow Jigs or Fixtures: up to 48" OD or to customer specifications

### 3. Outboard Roller Supports

- ✓ Modular design accommodates a range of roller top, base, and functionality options
- ✓ Typically up to 60" diameter and 16,000lbs capacity available

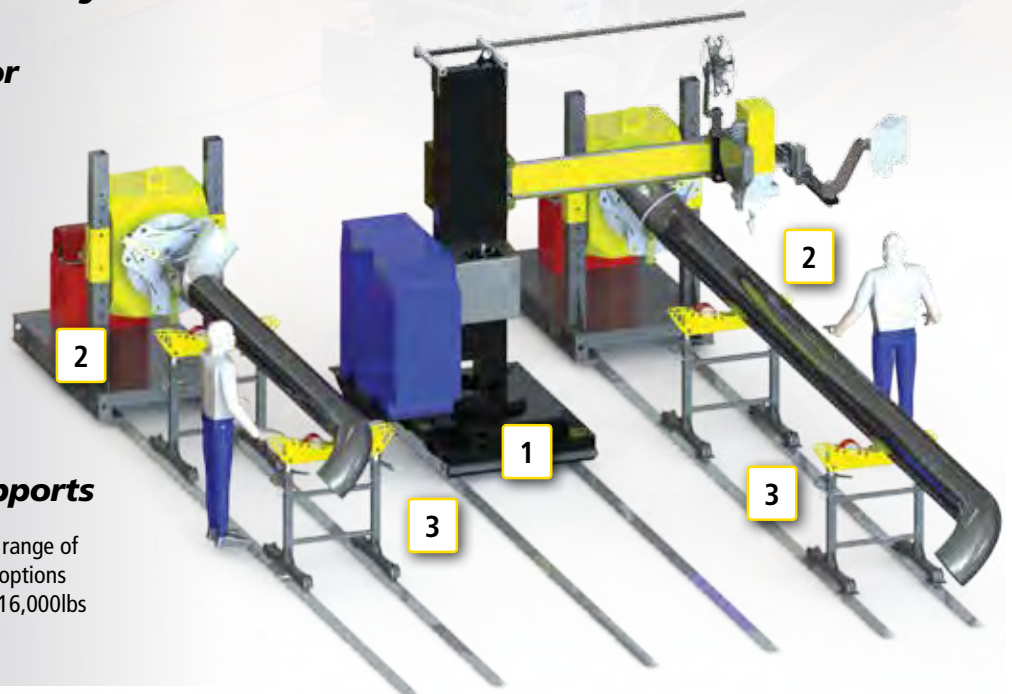

## Turnkey Welding Systems

LJ's unique modular and flexible design allows for multiple pieces of equipment to be integrated into fully automated welding cells. Integrated systems ranging from standard positioners, fixtures and manipulators through to fully automated robotic welding systems are available to suit any application.

### Subarc Overlay System



ACDC-1000 Submerged Arc manipulator integrated with custom 5-Ton capacity tilt positioner for high-deposition overlay rebuild of pipe mill rollers

### Aerospace Welding Manipulator and Positioner System



High precision aerospace GTAW+PAW welding manipulator with integrated servo positioner, used for welding of a variety of heat input sensitive turbine components. HMI interface, remote viewing camera and specialized Liburdi Automation welding system

### Robotic Welding and Positioner System

Fully integrated robotic welding process with coordinated motion tilt/rotate positioner, for up to 2,000lb high batch welding parts

- ✓ Ideal for high-volume repetitive welding
- ✓ Fully integrated positioner, fixture, robot and welding package options
- ✓ Easy to use



### Robotic Pipe Joining System

Fully integrated robotic welding process with servo positioner and material handling system for automated joining of heavy wall large bore pipe up to 60" diameter

- ✓ Servo headstock for precise rotation speed
- ✓ Full alignment capabilities for roller supports for quick fit up of weld joint
- ✓ Robotic welding system automatically tracks seam for maximum productivity

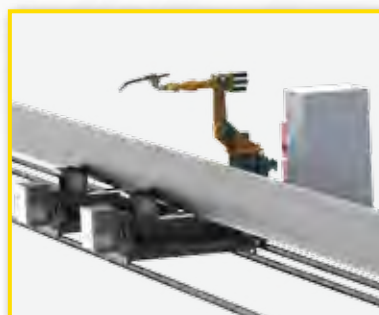

# Powered Headstock Positioners

Synchronized powered elevating head and tailstocks allow for maximum flexibility when lifting or rotating heavy workpieces such as trailer frames or large vessels.

**POWERED HEIGHT ADJUSTABILITY**

H6PS-100



H12PS-100



H24PS-100



SPECIFICATIONS	H6PS-100 6,000 lbs	H12PS-100 12,000 lbs	H24PS-100 24,000 lbs
Load Capacity:	6,000 lbs (at 12" overhung load)	12,000 lbs (at 12" overhung load)	24,000 lbs (at 12" overhung load)
Footprint:	60" x 42" x 95"	89" x 60" x 118"	96" x 71" x 122"
Turning Torque:	50,000 in-lbs	125,000 in-lbs	250,000 in-lbs
Height Adjustability:	32" – 72"	42" – 96"	42" – 96"
Power Requirements:	480V, 3-ph*, 10 AMP	480 V, 3-ph*, 20 AMP	480 V, 3-ph*, 20 AMP
Rotation Speed:	0.1–3.0 RPM	0.05–2.2 RPM (Other speed options available)	0.05–1.2 RPM (Other speed options available)
Ground Capacity:	800 Amps	1500 Amps	1500 Amps
Equipment Mass:	2,500 lbs	6,390 lbs	9,600 lbs

\* 208–600 V, 50 or 60 Hz input power options available. Ground Capacity: 200Amp, 400Amp, 800Amp, or 1500Amp available. Custom Height Range: to customer requirement. Specifications subject to change; consult factory for all specifications.

## Tailstocks Available With Heavy Duty Positioners

Headstock Model	Optional Tailstock	System Capacity	Height Adjustability
1PS-100	✓	2,000 lbs	Fixed
16P-700	✓	6,000 lbs	Manual coarse adjustable
30P-200	✓	12,000 lbs	Manual coarse adjustable
45P-500	✓	24,000 lbs	Manual coarse adjustable
P24PS-100	✓	48,000 lbs	Manual coarse adjustable
P60PS-200	✓	120,000 lbs	Manual coarse adjustable
H06PS-100	✓	12,000 lbs	Synchronized powered elevation
H12PS-100	✓	24,000 lbs	Synchronized powered elevation
H24PS-100	✓	48,000 lbs	Synchronized powered elevation



# Powered Height, Tilt & Rotate Positioners

LJ's 1HT-style positioner has the widest range of positions in its class, allowing for extremely low profile flat positions during loading and smooth powered adjustability for height, tilt and rotation axes.



SPECIFICATIONS	1HT-300 6,000 lbs
Load Capacity:	6,000 lbs
Footprint:	71" x 98" x 29"
Turning Torque:	40,000 in-lbs
Power Requirements:	480 V, 3-ph
Rotation Speed:	0.2-2 RPM
Height Adjustability:	25" x 72" Centerline height (hydraulically actuated height adjustability)
Range of Operation:	-45° to 90°
Ground Capacity:	800 Amps
Equipment Mass:	5,400 lbs

Available in any custom capacity, consult sales for details. Specifications subject to change; consult factory for specification requirements.



- ✓ Powered height, tilt, and rotation through compact hand pendant
- ✓ Best in class range of motion
- ✓ Compact design

## Features & Options

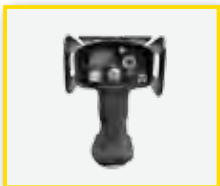

Cabled or wireless hand pendant with or without digital readout

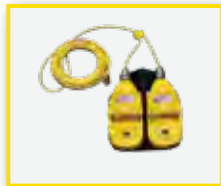

Bi-directional or variable speed foot switches



Grippers up to 60" OD



# Portable & Benchtop Positioners

LJ bench top positioners are available with a variety of features, such as:

- ✓ Air purge fitting for stainless steel or TIG welding applications
- ✓ Hollow spindle
- ✓ Height adjustable roller cart
- ✓ Torch mount options

**IDEAL FOR USE IN LIGHTER DUTY APPLICATIONS**

8P-200 Bench Top



12P-800 Thru - Bore



12P-900 Portable



SPECIFICATIONS	8P-200 Bench Top Positioner 300 lbs	12P-800 Thru - Bore Positioner 1,000 lbs	12P-900 Portable Positioner 1,000 lbs
Load Capacity:	300 lbs (at chuck face)	1,000 lbs (at chuck face)	1,000 lbs (at chuck face)
Footprint:	14" x 17" x 20"	26" x 26" x 26"	22" x 23" x 25"
Power Requirements:	110 V, 1-ph*	110 V, 1-ph*	110 V, 1-ph*
Speed Range:	0.7–7 RPM	0.45–4.5 RPM	0.5–5 RPM
Turning Torque:	730 in-lbs	3,000 in-lbs	3,000 in-lbs
Table:	12" OD table, 8" chuck optional	12" OD table, 12" chuck optional	12" OD table, 12" chuck optional
Ground Capacity:	200 Amps	200 or 400 Amps	800 Amps
Thru-Bore:	3/8" hollow spindle c/w air purge fitting	3" hollow thru-bore	3/8" hollow spindle c/w air purge fitting
Range of Operation:	Manually adjustable with handle -15° – 105° in 15° increments	Hand crank self locking worm gear tilt feature -5° – 105° range c/w angle gauge	Hand crank self locking worm gear tilt feature -5° – 105° range c/w angle gauge
Equipment Mass:	Positioner: 110 lbs, Chuck 39 lbs	Positioner: 190 lbs, Chuck 110 lbs	Positioner: 280 lbs, Chuck 110 lbs

\* 208–680 V, 50 or 60 Hz input power options available. Positioner must always be mounted to a suitable base. Specifications subject to change; consult factory for all specifications.

## 12LT-200 Scissor Lift Cart 1,600 lbs

Capacity:	1,600 lbs
Footprint:	42" x 40" x 26"
Height Range:	26" – 42"
Roller Base:	Swivel lock urethane casters
Equipment Mass:	400 lbs

Key Features: Tilt, Height Adjustable, & Portable



## Features & Options

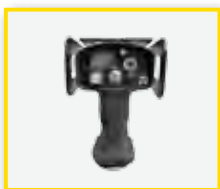

Cabled or wireless hand pendant with or without digital readout

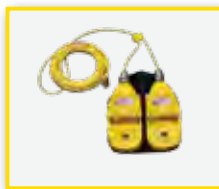

Bi-directional or variable speed foot switches

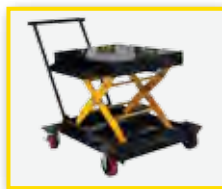

Portable scissor lift cart



## Low Profile Turntables

Low profile turntables are used for precise positioning in the flat or horizontal position. LJ's ultra-low profile turntables are the lowest profile turntables available on the market.

AVAILABLE IN ANY  
SIZE OR CAPACITY



TRN10-200



TRN40-100

## Low Profile Turntables

SPECIFICATIONS	TRN2-200 2-Ton	TRN10-200 10-Ton	TRN20-200 20-Ton	TRN30-200 30-Ton	TRN40-100 40-Ton
Load Capacity:	4,000 lbs (Up to 8" eccentricity)	20,000 lbs (Up to 6" eccentricity)	40,000 lbs (Up to 6" eccentricity)	60,000 lbs (Up to 12" eccentricity)	80,000 lbs (Up to 12" eccentricity)
Footprint:	33" x 25" x 12"	48" x 41" x 16"	48" x 41" x 16"	48" x 41" x 16"	120" x 120" x 44"
Table Size/Span:	30"	48"	48"	60"	120"
Power Requirements:	110 V, 1-ph*	110 V, 1-ph*	110 V, 1-ph*	480 V, 3-ph*	480 V, 3-ph*
Rotation Speed:	0.1–1.5 RPM	0.3–3.3 RPM	0.3–3.3 RPM	0.2–2.0 RPM	0.05–1.2 RPM
Ground Capacity:	400 Amps	800 Amps	800 Amps	800 Amps	800 Amps (1500 or 2000 also available)
Equipment Mass:	450 lbs	1,350 lbs	1,500 lbs	6,500 lbs	12,350 lbs

\* 208 - 600 V, 50 or 60 Hz input power options available. Custom Height Range or powered height adjustability. Ground Capacity: up to 2500 Amp available. Specifications subject to change; consult factory for all specifications.

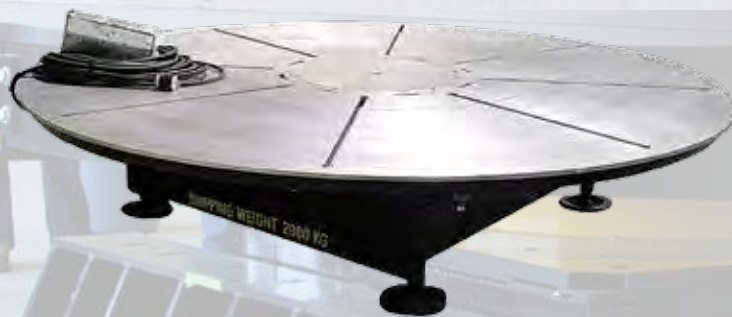

## Custom Turntables

- ✓ Table size up to 16 ft diameter any style
- ✓ Capacity up to 100 tons
- ✓ Any speed range or precision

## Features & Options

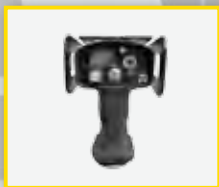

Cabled or wireless hand pendant with or without digital readout

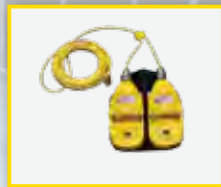

Bi-directional or variable speed foot switches



## Grippers & Chucks

High-quality, cost-effective welding grippers and chucks are a standard accessory on all welding positioners.

3-jaw self centering scroll chucks with reversible top jaws available in 8", 12", 16" gripping diameter ranges

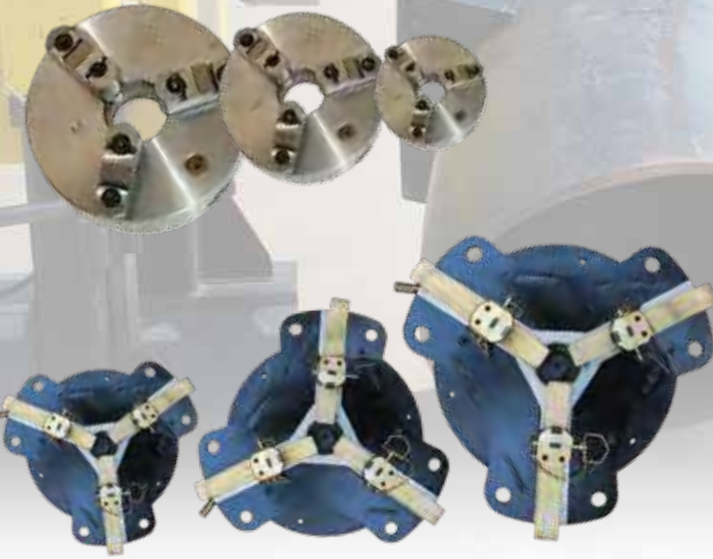

**HIGHEST CAPACITY GRIPPERS AVAILABLE ON THE MARKET**

For oversized or heavy gripping requirements with smooth, serrated or carbide insert top jaws

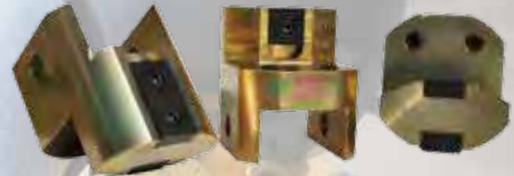

### Gripper Options

SPECS	T30-200	T50-200	T60-100
Load Capacity:	5,000 lbs	10,000 lbs	10,000 lbs
Diameter Range:	2" – 30"	2" – 50"	2" – 60"

V72-100 Gripper now available for up to 72" OD & 24,000 lbs load capacity

**SAFER, EASIER ELBOW FIXTURING**



## Elbow Jigs

SPECS	Elbow Jigs (2" – 48")															
	02E-200	03E-200	04E-200	06E-200	08E-200	10E-200	12E-200	14E-200	16E-200	18E-200	20E-200	24E-200	30E-200	36E-200	42E-200	48E-200
Nominal Diameter:	2"	3"	4"	6"	8"	10"	12"	14"	16"	18"	20"	24"	30"	36"	42"	48"
Capacity:	250 lbs	250 lbs	250 lbs	250 lbs	500 lbs	500 lbs	500 lbs	500 lbs	1,000 lbs	1,000 lbs	1,000 lbs	1,000 lbs	2,000 lbs	2,000 lbs	2,000 lbs	2,000 lbs

45° and 90° Elbows: Precision fit and clamp allows for quick and easy fitting, prepping and welding of elbows for use with welding positioners.



Remove hold down u-bolt



Load elbow into jig



Measure the fit



Fasten elbow into the jig

# Automation & Controls

## Controls Panels

- Input power supply: 110-600 Volts and 50/60 Hz optional
- Master variable speed, direction, on/off local/remote controls
- PLC based HMI touchscreen or conventional push button controls to customer preference



## FS-FR

### Forward/Reverse Foot Switch

- Heavy Duty Cast steel body with heavy duty guard/handle
- Momentary actuation (normally off)
- Heavy rubber 8 m (25 ft) cable with 4-pin metal plugs



## HP-100

### Single/Dual Axis Hand Pendants

- Ergonomic, easy to use, lightweight design, c/w protective guard
- Optional LCD digital speed readout
- Heavy rubber 8 m (25 ft) cable with 19-pin metal plugs



15 m (50 ft) Extension Cables Available



## FS-V

### Variable Speed Foot Switch

- Plug & Play with optional controller upgrade
- Main panel controls master speed range, foot switch used for variable speed in master range



## Wireless Pendants

- For multiple-axes control or complex functions

# Automation Capabilities

LJ utilizes user-friendly touch screen controls for plug and play integration of multiple machines to create fully integrated welding and material handling systems.



Fully integrated automated welding systems

## User friendly HMI Control



Robotic or fixed welding automation



Material handling systems

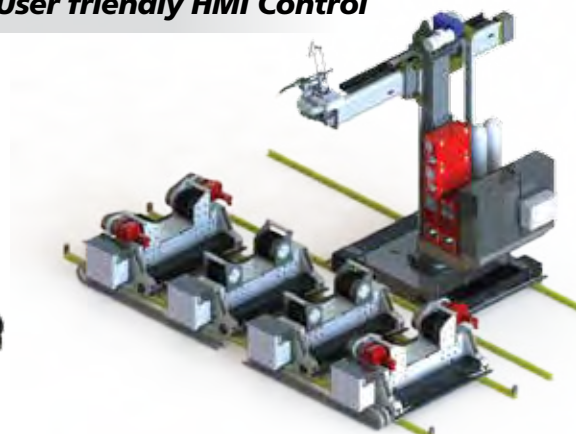

# Pipe & Structural Steel Conveyor Systems

LJ manufactures extra heavy duty pipe and material handling shuttles with numerous unique safety and functionality advantages including: wireless control, safety e-stops, large capacity and variable speed controls features.

SPECIFICATIONS	LDPC-100 1-16"	HDPC-100 1-40"
Load Capacity:	1,000 lbs per section	8,000 lbs per section
Diameter Range:	1" – 16"	1 – 40"
Footprint:	15" x 120" x 36"	43" x 120" x 40"
Torque Limiter:	35 ft-lbs Max	285 ft-lbs Max
Power Requirements:	240 V	240 V
Traverse Speed:	40 ft/min	40 ft/min



LDPC-100



HDPC-100

Large bore conveyor for up to 40" OD pipe



Small bore conveyor for up to 16" OD pipe

# Pipe Handling Systems

LJ designs and builds custom pipe handling systems for applications ranging from barge pipe lay to custom lathe support rollers.

## Engineering Rendering To Finished Product



SPECIFICATIONS	HZH-200 100-Ton Custom Hose Handling System
Load Capacity:	200,000 lbs (100-ton) per set of 10 roller assemblies
Diameter Range (of hose/piping assembly):	4" – 42" OD
Rollers:	Urethane covered steel rollers
Equipment Mass:	10,560 lbs

*Modular and portable design, marine grade components. Specifications subject to change; consult factory for all specifications.*

# Cable Reel Rollers

Cable Reel Rollers are used for rolling large cable spools, for payout, unwinding and take-up of heavy cable. LJ engineers & manufactures cable reel rollers to any capacity or specification required.



SPECIFICATIONS	CRR55-100 10 Ton Cable Reel Roller	CRR68-100 15 Ton Cable Reel Roller	CRR810-100 40 Ton Cable Reel Roller
Load Capacity:	20,000 lbs	30,000 lbs	80,000 lbs
Spool Size Range:	2-8 ft diameter 5 ft-3 in max width	2-12 ft diameter 8 ft max width	5-16 ft diameter 10 ft max width
Tractive Effort/Torque:	2,150 lbs	3,000 lbs	8,500 lbs
Rotation Speed:	30-780 in/min	48-480 in/min	48-480 in/min
Height Range:	Low Profile, fine adjust leveling feet optional	Low Profile, fine adjust leveling feet optional	Low Profile, fine adjust leveling feet optional
Power Requirements:	240 V, 1-ph*	240 V, 1-ph*	480V, 3-ph*
Equipment Mass:	2,200 lbs	3,015 lbs	6,700 lbs
Footprint:	79" x 95" x 29"	99" x 134" x 22"	102" x 156" x 43"

\* 208 - 600 V, 50 or 60 Hz input power options available. Specifications subject to change; consult factory for all specifications.

## Features & Options

Variable speed drive for rotational speed adjustability; input power supply to customer needs

Adjustable reel alignment guides

Slip clutch for gearbox and over-torque protection

Top quality motor/gear train, heavy duty frame

Quick adjust carriage for diameter settings

Leveling feet (optional)  
\*Optional anti-tipping safety catch (not shown)



Best in class performance and safety features

# Beam Clamp Rigging Rollers

Pipe rigging rollers are used for a variety of applications, in particular for installation of pipe into racks at refineries, power plants, and other industrial facilities.

Standard features:

- ✓ Quick clamp system for 5-12" structural beam flange range
- ✓ Handles for easy moving
- ✓ Heavy duty roller system

**SAFER, FASTER, EASIER  
INSTALLATION OR REMOVAL OF PIPE**



MDRN-200



HZ6-200



HZ2-100



HZD-100



HZDD60-200

## SPECIFICATIONS

	MDRN-200 1-Ton Unidirectional	HZ6-200 1-Ton Unidirectional	HZ2-100 2-Ton Unidirectional	HZD-100 5-Ton Unidirectional	HZDD60-200 10-Ton Unidirectional
<b>Load Capacity:</b>	2,000 lbs	2,000 lbs	4,000 lbs	10,000 lbs	20,000 lbs
<b>Diameter Range:</b>	2" – 8"	2" – 24"	2" -16" (2-32" optional)	2" – 42"	24" – 60"
<b>Equipment Mass:</b>	40 lbs	94 lbs	85 lbs	95 lbs	222 lbs
<b>Shipping Dimensions:</b>	15" x 10" x 5"	26" x 15" x 9"	31" x 15" x 10"	26" x 15" x 7"	41" x 16" x 11"

MDRN-100



Extra small footprint or extra large capacity options are available

MDR-200



MDR-700



Handles for safe & easy lifting for installations

## SPECIFICATIONS

	MDRN-100 1-Ton Multi-Directional	MDR-200 1-Ton Multi-Directional	MDR-700 2-Ton Multi-Directional
<b>Load Capacity:</b>	2,000 lbs	2,000 lbs	4,000 lbs
<b>Diameter Range:</b>	2" – 8"	2" – 24"	4" – 36"
<b>Equipment Mass:</b>	40 lbs	60 lbs	80 lbs
<b>Footprint:</b>	15" x 9" x 5"	15" x 22" x 6"	15" x 25" x 7"

Specifications subject to change; consult factory for all specifications.

## Features & Options



Convenient and safe clamp system for quick damage-free mounting to structural beams



Optional beam-clamp lifting jacks for quick lifting/lowering of pipe on or off roller systems



Available with jacking systems to load or offload rollers easily

# Pipeline Roller Equipment

Pipeline rollers are designed to protect, support, and guide a pipeline section during river and road crossings. Pipe guide rollers help minimize drag forces of pipe-pulling through horizontally drilled or bored holes. LJ manufactures conical or conveyor roller style pipe rollers for applications ranging from 2" light walled HDPE piping up to heavy walled 72" steel pipe with capacities ranging from 2,000 to 80,000 lbs or greater.



SPECIFICATIONS	HZ6-300 1-Ton, 2–24" OD	HZM5-200 5-Ton, 4–48" OD	HZM10-200 10-Ton, 4–48" OD	HZM405-100 40-Ton, 4–72" OD
Load Capacity:	2,000 lbs	10,000 lbs	20,000 lbs	80,000 lbs
Diameter Range:	2" – 24"	4" – 48"	4" – 48"	4" – 72"
Footprint:	26" x 16" x 8"	61" x 30" x 22"	63" x 43" x 22"	71" x 56" x 32"
Equipment Mass:	90 lbs	600 lbs	1,100 lbs	1,725 lbs
Roller Style:	Single setting urethane cone rollers	2 urethane side rollers, 1 horizontal roller (optional)	4 urethane side rollers, 2 horizontal rollers (optional)	8 urethane side rollers, 2 horizontal rollers (optional)

## Pipeline Cradles

LJ Roller Cradles are used as an effective method for supporting and rolling pipe at the entrance of pipeline crossings. The cradle safely supports, guides, and protects the pipe.



SPECIFICATIONS	PRC-100	PRC-200	PRC-300
Load Capacity:	28,000 lbs	50,000 lbs	62,000 lbs
Diameter Range:	12" – 24" pipe	24 – 36" pipe	36" – 48" pipe

Specifications subject to change; consult factory for all specifications.



## ABOUT US

LJ Welding Automation specializes in the engineering and manufacturing of positioning, welding automation and material handling equipment. LJ services and supports customers in diverse industries including oil & gas, pipelines, mechanical contractors, aerospace, wind power and more, with installations in over 40 countries around the world.

## ENGINEERING

3D CAD software (Solidworks™) is utilized by LJ's engineering team for all detailed design. Customers have input from concept through to final shop drawings, which ensures that the customer receives quality engineering design with input all the way through the design process. LJ is an APEGA-licensed company.

## MANUFACTURING

LJ operates out of two company owned buildings with over 45,000 sq ft manufacturing space and 4.5 acres of land. Our ISO 9001:2008 and CSA certified manufacturing facility is fully equipped with robotic welding and CNC machining centers, while our sister company Automated Metal Processing (AMP) provides highly automated laser cutting and metal processing services.

## THOUSANDS OF INSTALLATIONS IN OVER 40 COUNTRIES AND 6 CONTINENTS



### Contact information:

Ph: +1 (780) 466-6658      4747 – 76th Ave  
Fax: +1 (780) 469-6710      Edmonton, Alberta  
info@LJwelding.com      Canada T6B 0A3  
www.LJwelding.com



**ISO 9001:2008 Certified**